

TECSYSTEM S.r.l®

INSTRUCTION MANUAL

T-935-FO ANALOGUE

TECSYSTEM S.r.l.
Via Cristoforo Colombo, 5/C
20094 Corsico (MI)
tel. +39 - 02 - 48601011 / 4581861
Fax: +39 - 02 - 48600783

<http://www.tecsystem.it>

R.2 11/02/03

T-935-FO ANALOGUE protection relays

1) ANALOGUE OUTPUT 4-20 mA TRANSMISSION

Due to the introduction of more and more sophisticated long-range control devices of variables such as the working temperature of Medium Voltage transformers and to their more elaborate protection system, it was necessary to develop our new monitoring unit, Mod. T-935 FO/ANAL.

Through a special electronic circuit this unit sends an analogue signal (4-20 mA) within the set temperature range (0-200°C).

This analogue signal can be handled in two different ways:

- it can be sent at distance to an analogue temperature display either electromechanical or electronic.
- it can be sent to a pc, through an A/D conversion card to be later sent to a more sophisticated monitoring system.

In order to make the signal transport system more reliable the T935 FO/ANAL unit is equipped with an external power supplier operating the Pt100/4-20 mA signal conversion card inside the unit.

There are two kinds of power suppliers: one with a fixed voltage 220VAC input (Mod. A420); the other with the universal voltage input, from 20 to 240 VAC-DC (Mod. AU420). The output voltage is 24 VDC.

See figure no.2 for power supplier connection to T935 FO/ANAL unit.

MOD.AU420

Universal input voltage: from 24V to 240V AC/DC 50/60Hz

Power required: 1.5 VA

Output voltage: 24 VCC ±5%

Max. current delivered: 50 mA

Dimension: 100 x 105 h 56 mm

ABS self-extinguishing housing

Galvanic insulation between IN-OUT 250-0 VAC

Operating temperature: from 0 to 60°C max.

Max. ambient humidity: 90%RH no condensing

Fault signal relay for lack of input voltage

2) TECHNICAL SPECIFICATIONS

<p>AUXILIARY POWER SUPPLY</p> <ul style="list-style-type: none"> • Rated voltage 24-240 Vac-dc • Maximum ratings 20-270 Vac-dc • Vdc with reversible polarities 	<p>COMMUNICATION</p> <ul style="list-style-type: none"> • Not available in this model
<p>INPUTS</p> <ul style="list-style-type: none"> • 4 inputs RTD Pt100 sensors-3 wires • removable rear terminals • input channels protected against electro-magnetic noises and spikes • sensors length cables compensation up to 500 m (1 mm²) • opt. Analog inputs 4-20 mA (range 0-200°C) 	<p>OUTPUTS</p> <ul style="list-style-type: none"> • 2 alarm relays (ALARM-TRIP) • 2 alarm relays for fan control (FAN1-FAN2) • 1 alarm relay for sensor fault or working anomaly (FAULT) • output contacts capacity: 5A-250Vac res. • Output relays test
<p>TESTS AND PERFORMANCES</p> <ul style="list-style-type: none"> • Assembling in accordance with CE rules • Protection against electrical and magnetic noises CEI-EN50081-250082-2 • Dielectric strength: 2500 Vac for 1 minute from relays to sensors, relays to power supply, power supply to sensors • Accuracy: ± 1% full scale, ± 1 digit • Ambient operating temperature -20°C to +60°C • Humidity 90% no-condensing • ABS self-extinguishing housing-NORYL 94VO • Frontal polycarbonate-IP65 • Burden 3VA • Data storage 10 years minimum • Digital linearity of sensors signal • Self-diagnostic circuit • Opt. Frontal plastic protection • Opt. Protection treatment of electronic part 	<p>DISPLAYNG AND DATA MANAGEMENT</p> <ul style="list-style-type: none"> • 1 display 13mm high with 3 digits for displaying temperatures • led for displaying reference channel • led indicating alarm or trip channel • led indicating fault • temperature monitoring from 0°C to 200°C • 2 alarm thresholds • 2 alarm ON-OFF thresholds for fan control • sensors diagnostic (Fcc-Foc- Fcd) • entering the programming by frontal push button • automatic output from programming cycle after 1 minute of no-operation • wrong programming automatic display • programmed data call out • possibility of set automatic channel scanning, hottest channel, manual scanning • maximum temperatures and alarm reached storage • frontal alarm RESET push button • possibility of set HOLD function for output relays
<p>DIMENSIONS</p> <ul style="list-style-type: none"> • 96X96MM-DIN43700-prof. 140mm (with rear terminals) • panel cutout 92x92mm 	

3) MOUNTING

Make a hole with the dimensions of 92x92 mm in the panel plate.
Fasten firmly the unit by the fixing blocks you are equipped with.

4) POWER SUPPLY

The T-935 unit has a Universal Power Supply: it can be supplied indifferently from 24 to 240 Vac-dc without any respect to the polarities.

This feature is obtained by the application of a tried power supplier which provides the installer free from the worries concerning the correct Vac or Vdc power supply.

The ground cable must always be fixed to the clamp 41.

When the unit is supplied directly from the secondary of the transformers to protect, it can be fulminated by high intensity overvoltage.

This happens when the locking of the master switch is connected without charge.

This is much more evident when the 220 Vac voltage is obtained directly from the bars of the secondary of the transformers and there is a fixed phase adjustment condenser of the same transformer.

*In order to protect the electronic apparatus, we recommend the application of the electronic discharges of the series PT-73 - mono or double phase - which have been studied by Tecsystem Srl for this specific purpose.
Alternatively, we recommend the application of a power supply by 24 Vac or better 24 Vdc.*

5) ALARMS AND FAN CONTROL ELECTRICAL CONNECTIONS

Carry out the electrical connections on the extractable terminal board after having taken them off from the apparatus (follow the Fig.1).

ALARM and TRIP relays energize only when the prefixed temperature limits are reached.

The FAULT relay energizes when the apparatus is supplied and it de-energizes when the Pt100 are damaged or when there is no power supply voltage.

FAN 1 and FAN 2 relays can be used for cooling-fan control or else they can be fit into the conditioning circuit of the transformer box.

6) THERMOMETRIC SENSORS CONNECTION

Each Pt100 sensor has three conductors : one white and two red (CEI 75.8)

The Fig.1 shows the disposition in the terminal board of the connection cables to the unit.

The CH2 channel must be always refired to the central column of the transformer.

The CH4 channel must be always refired to the core of the transformer or else to the ambient Pt100 sensor, if you want to keep the box of the transformer under thermic control by the T- 935 unit.

7) MEASURE SIGNALS TRANSPORT

All the transport cables of the Pt100 measure signals must absolutely:

- be divided from the power ones
- be realized with shielded cable with twisted conductors
- have a section of min 0,5 mm²
- be twisted if you have no shield
- be firmly fixed in the terminal board
- have tinned or silvered conductors

All the "T" series units have the sensors linearization with a max error of 1% v.f.s..

*TECSYSTEM srl has realised a special cable for the measure signal transport with all the protection requirements according to CEI Norms: **mod. CT-ES***

8) THERMOMETRIC SENSORS DIAGNOSTIC

In case of damage of one of the thermometric sensors which are installed on the machine to protect, the **FAULT** relays energizes immediately, the ALARM and TRIP LED of the damaged channel (Chn) lighten and the **FAULT LED** is lightening.

The kind of sensor damage will automatically appear on the display. It can be:

- **Fcc** if the sensor is in short circuit
- **Foc** if the sensor is disconnected

9) SENSOR TEST DEVICE Fcd (damaged sensor)

During the normal working of the unit, if you programmed **Fcd**/YES the display will signal by **Fcd** that a sensor is damaged and the LED which corresponds to the respective channel will lighten (Chn).

The **FAULT** relay energizes giving a signal to the operator.

After the replacement of the damaged sensor, you can RESET the alarm pushing RESET until **RST** appears on the display.

10) TEMPERATURES DIAGNOSTIC

When one of the thermometric sensors surveys a temperature which is 1°C above the alarm limit, after 4 seconds the **ALARM** relay will energize and the ALARM LED of the respective channel (Chn) will switch on.

We have the same situation when the TRIP temperature limit is surveyed: we have the energizing of the **TRIP** relay and the lighting of the LED TRIP of the respective channel (CHn).

Then the surveyed temperature falls of 1°C below the prefixed limit for the **ALARM** and **TRIP** switching, the relays deenergize and the respective LEDS switch off.

11) COOLING-FAN CONTROL

The T-935 FO/ANAL unit, if suitably programmed, can control the ON/OFF condition of the transformer fans according to the two different levels of set temperatures. The transformer side-fans or the air-drifting fans can be controlled in two different ways:

- using the temperatures surveyed by the sensors on the three columns
CHF 1.2.3 - CH4 excluded
ALARM and TRIP LED CH1.2.3 switched on (ex. F1: ON at 80°C - OFF at 70°C)
(ex. F2: ON at 90°C - OFF at 79°C)
- by an additional sensor (**CH4/YES**) for the ambient temperature in the transformer box.
CHF 4
ALARM e TRIP LED Ch4 switched on (ex. F1: ON at 40°C - OFF at 30°C)
(ex. F2: ON at 45°C - OFF at 35°C)

You can select it by UP and DOWN push-buttons.

12) FAN TEST

By programming (**hxx**) you can establish to have the fans set for 5 minutes every "xx" hours, independently on columns or ambient temperature values.

This function has the purpose to verify periodically the fans working, when they are not utilized.

Establishing **h00** this functions is excluded.

13) HOLD FUNCTION

If you set up by programming HLD-YES, ALARM and TRIP relays will be energized until the manual reset when the temperature falls down below the set alarm thresholds. If you do not want this function you have to establish HLD no by up and down push-buttons.

14) DISPLAY MODE

Pressing on DISPLAY MODE you establish the visualization ways of the display:

- **HOT**: the unit visualizes automatically the hottest channel
- **MAN**: manual reading of the channels temperature by UP and DOWN push-buttons
- **T.MAX**: the unit visualizes the max. temperature reached by the sensors and the possible alarms starting from last reset. To check the channels press UP and DOWN.
- **SCAN**: channels are ciclely every 2 seconds

15) WORKING PROGRAM CONROL

In order to control the programmed temperature values, you have to push shortly on PRG. By pushing PRG repeatedly the values previously established appear on the display in sequence.

In order to end the visualization you have to push ENT.

16) LAMP TEST

It is advisable to carry out regularly the LED test of the unit. For this operation you have to push TEST.

If one of the LEDS does not work, please send us the unit in order to be repaired.

17) ALARM RELAYS TEST

This function allows to test the relays working without any additional instrument. To carry out the test you have to push TEST for 5 seconds: all the LED will switch on and **tSt** lightening will appear on the display. Release it when the RELAY TEST LED will be alight. The first relay to test will be indicated by the display and the respective LED will be alight. The relays to test will be indicated on the display by:

- **"Fan 1"**: 1st cooling relay
- **"Fan 2"**: 2nd cooling relay
- **"Flt"**: Pt100 fault relay
- **"Alr"**: alarm relay
- **"trP"**: trip relay

Select the relay to test by UP and DOWN push-buttons. Energize it by pushing SET and de-energize it by pushing RESET. In order to stop this procedure, you have to push again TEST and all the relays will be restored to the starting configuration. After 5 minutes of inactivity of the keyboard, the TEST RELAY procedure will be automatically interrupted.













18) ALARM RELAY EXCLUSION

If you want to exclude the alarm signal, you have to push RESET: the relay de-energizes and the respective LED, which was alight, starts to lighten. If the transformer temperature is still rising, the ALARM relay will energize again until the temperature value falls down to 5°C below TRIP threshold. In this moment the user can exclude the ALARM again, but in this case, it will not appear any other indication as regards to ALARM relay. The exclusion system will be automatically disconnected when the temperature falls down the ALARM threshold.

19) IMPORTANT NOTICE

Before making the insulation test on the electrical panel on which the unit is installed, you must take it off from the power supply in order to keep it out of damage.

20) PROGRAMMING

N°	PUSH BUT-TONS	EFFECT	NOTES
1	PRG/SET	Keep the push button pressed for 7" until Set appears and PRG starts to lighten. When PRG stops lightening the set DEFAULT ALARM temperature will appear on the display	Led program allight
2		set up the established limit for CH 1-2-3	
3	PRG/SET	TRIP set T° appears	
4		set up the established limit for CH 1-2-3	
5	PRG/SET	on display appears CH4	
6		set up CH4 YES or NO	YES: CH4 connected NO: CH4 disconnected
7	PRG/SET	ALARM set T° appears	only if YES was chosen at step 6.
8		Enter the desired Trip setpoint for Ch 4	
9	PRG/SET	TRIP set T° appears	only if YES was chosen at step 6.
10		Enter the desired Trip setpoint for Ch 4	
11	PRG/SET	"FAN" appears	
12		set up FAN YES or NO	YES:FAN connected NO: FAN disconnected
13	PRG/SET	way of FAN control on the display appears CHF	only if YES was chosen at steps 6 and 12.
14		set up CH 1,2,3 or CH4	respective LED alight
15	PRG/SET	on the display appears On	
16	PRG/SET	the On T° appears	
17		set up the temperature	only if at the step 12 you established YES
18	PRG/SET	on the display appears OFF	
19	PRG/SET	the OFF T° appears	
20		set up the temperature	only if at the step 12 and you established YES
to set up FAN2 repeat the same procedure as FAN1			
21	PRG/SET	way of FAN control TEST on the display appears h00	
22		set up the number of hours	only if at the step 12 you established YES h00=function disconnected
23	PRG/SET	on display appears Fcd	
24		set up Fcd YES or no	Fcd YES= control of damaged Pt100 connected
25	PRG/SET	on display appears Hld	
26		set up Hld YES or no	with Hld YES function HOLD established
27	PRG/SET	Prg appears on display	
28		set up Prg YES or NO	Prg NO= the programming is blocked
29	ENT	out of the programming	lamp test
30	PRG/SET	return to step 1	

TECSYSTEM S.r.l ®

21) PROGRAMMING REHABILITATION IN CASE OF BLOCK (Prg → no)

If the programming has been blocked (step 28), in order to enter again the programming of the unit, it is necessary to carry out the following unblocking procedure :

- enter the program vision way pushing PRG
- keep TEST pushed until PRG stops to lighten. (LED PROGRAM alight)

During the blocking, pushing PRG for more than two seconds, on the display “noP” appears to indicate the impossibility to program the data.

22) WARRANTY

The “T” series units are under warranty for 12 months from the delivery date marked on the unit.

The warranty is recognised when the unit breaks down due to some production faults or insufficient calibration.

The warranty is not valid when the unit is tampered with or when it has been damaged for a wrong sensors connection or wrong power supply, out of the max working limits (20÷270 Vac-dc). The warranty is not valid when the unit has been fulminated by excessive transitory voltages. In this case TECSYSTEM Srl does not answer for damages caused by faulted or defective units. All the delivery expenses (there and back) of the unit must be payed by the Customer.(ANIMA prices, Col. C.).

In case of dispute, the qualified FORUM is the one in Milan.

The warranty is always EXW our Company in Corsico.

23) PT100 EXTENSION CABLE: TECHNICAL SPECIFICATIONS

Cable 20xAWG 20/19 cu/stg

Section 0,55 mm²

Antiflame Insulation PVC105

In accordance with CEI 20.35 IEC 332.1

Max. working temperature: 105°C

Conformation : 4 terns of the numbered conductors (1-1-1.....4-4-4)

RRB twisted and coloured conductors

Shield cu/stg

PVC Antiflame protecting covering

External diameter 9,0 mm

Skeins of 100 m

TECSYSTEM S.r.l®

FAULT DIAGNOSTIC	CAUSES AND REMEDIES
The unit doesn't switch on even if there is voltage to the terminals	Connector not well fit in its place. Connection wires not well closed in the clamp Burnt power supplier. <i>Take away and give voltage again.</i>
The CH4 is in FAULT FOC (Only three Pt100 sensors are connected)	Wrong programming of the unit. <i>Repete the programming.</i>
One of the 3/4 channels is in FAULT for FOC/FCC	Check the sensors Pt100 connection. Probable damaged sensor. <i>Substitute the damaged sensor</i>
During the main switch manoeuvre ON-OFF, the ALARM and TRIP relays energize	Strong electrical noises on the power supply line. <i>Plug in the PT-73.</i> Check if the shield of the signal transport cable is connected to the ground on the side of the panel. <i>If you have no shielded cable, you have to put it. (Mod. CT-ES).</i> <i>If it is not available, twist the three connecting wires of the sensors.</i>
All the Pt100 sensors are in FCC.	Wrong connection of the sensors. Upside-down terminal board. <i>Check the connections and the terminal board</i>
The temperature indicated by 1 or more channels is wrong.	Contact Technical Dept. of TECSYSTEM S. r.l.
Sudden release of the main switch with a normal temperature level. A single channel caused the unhooking.	Pt100 sensor defective (Fcd). <i>Substitute the sensor. Check the measure signal terminal board.</i> <i>Set "Fcd" function (see page 5). Should the Fcd Fault signal appear on the display again, change the indicated sensor.</i>

FIG.1 *ELECTRICAL CONNECTIONS T-935*

Pt100 SENSOR CONNECTION

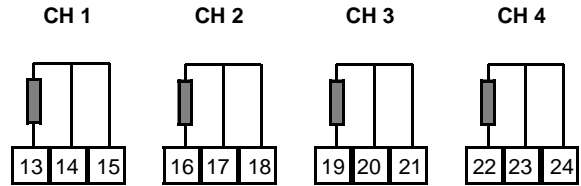

ALARM AND FAN RELAYS CONNECTION

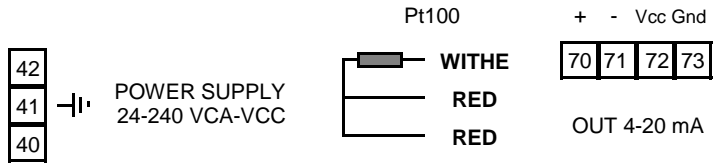
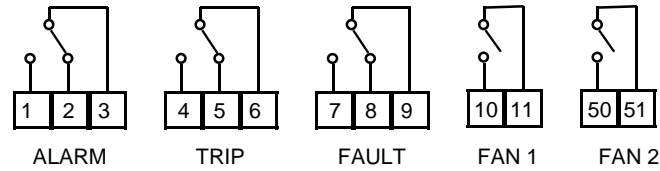
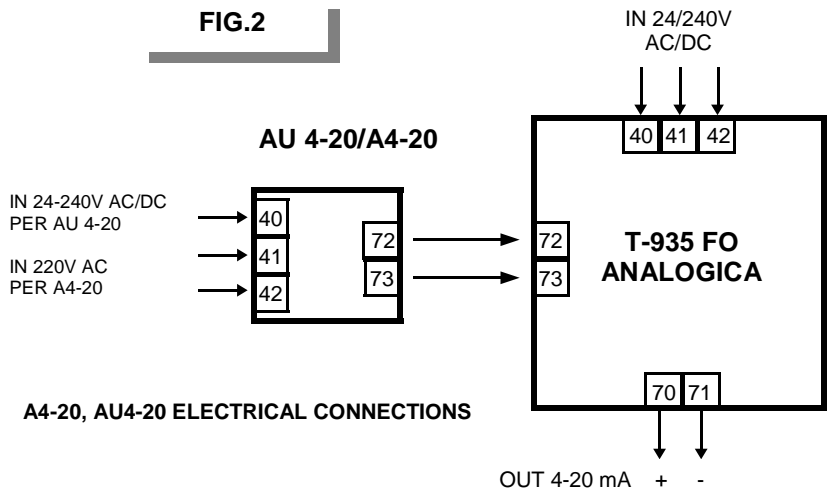

FIG.2



T-935-FO ANALOGUE TEST DESCRIPTION

The unit was submitted to the following tests during production:

N°	Description
1	PC board test
2	Input test
3	Test of relay contacts and outputs
4	Key test
5	Lamp test
6	Calibration at 100 and 200°C (for temperature monitoring units)
7	Software test
8	Burn-in minimum 24h

Date of shipment: