

TECSYSTEM S.r.l®

INSTRUCTION MANUAL

MM-286

TECSYSTEM S.r.l.
Via Cristoforo Colombo, 5/C
20094 Corsico (MI)
tel. +39 - 02 - 48601011 / 4581861
Fax: +39 - 02 - 48600783

<http://www.tecsystem.it>

R.3 29/01/03

MM-286 protection relays

TECSYSTEM S.r.l.®

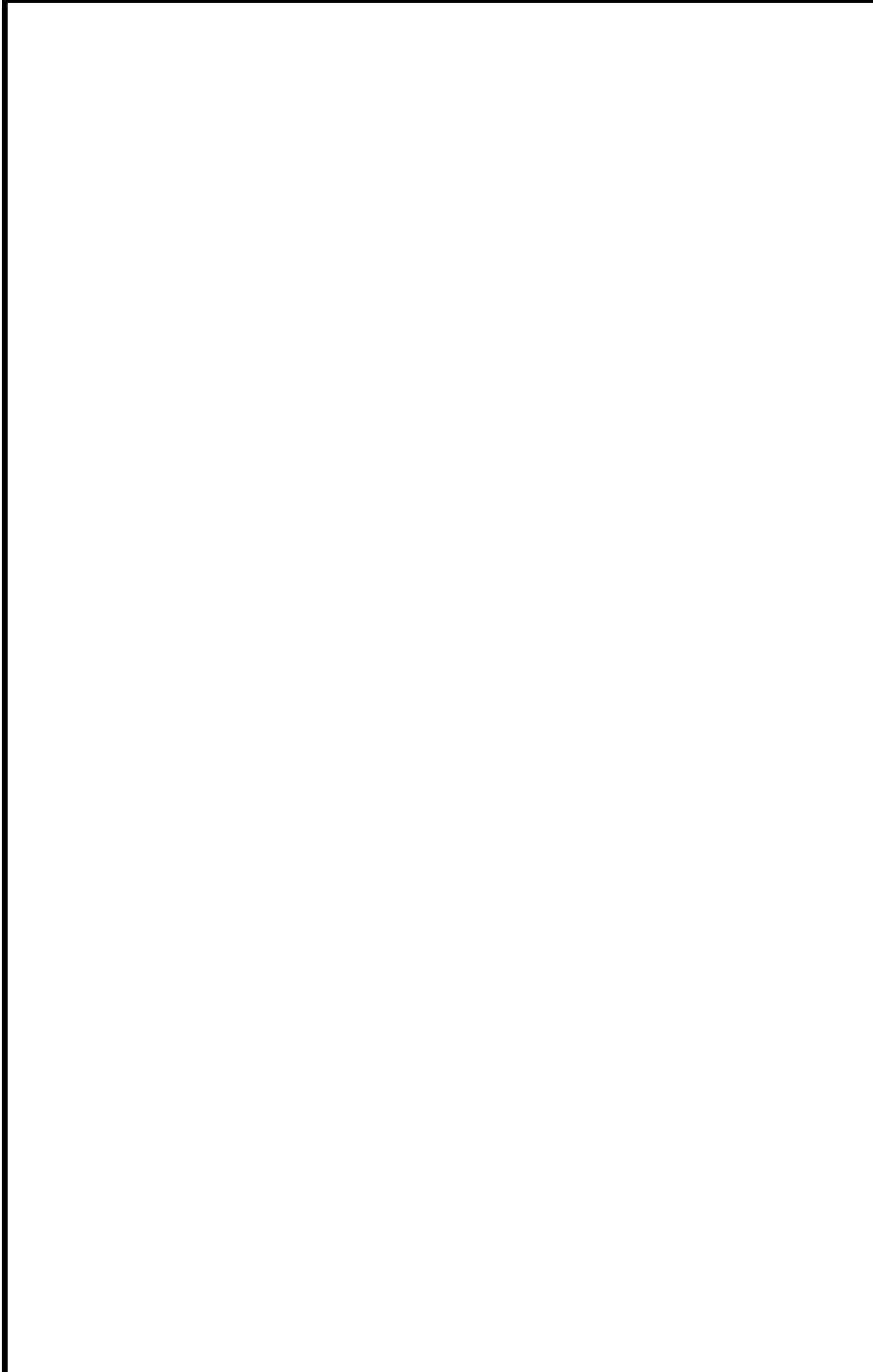

1) TECHNICAL SPECIFICATIONS

<p>AUXILIARY POWER SUPPLY</p> <ul style="list-style-type: none"> • Rated voltage 24-240 Vac-dc • Maximum rating 20-270 Vac-dc 	<p>COMMUNICATION</p> <ul style="list-style-type: none"> • Opt. Output RS232/485 Modbus@RTU
<p>INPUTS</p> <ul style="list-style-type: none"> • 6 inputs RTD Pt100 sensors-3 wires subdivided into: <ul style="list-style-type: none"> - 3 for windings - 2 for bearings - 1 for cooling air • removable rear terminals • input channels protected against electromagnetic noises and spikes • sensors lenght cables compensation up to 500m (1mm²) 	<p>OUTPUTS</p> <ul style="list-style-type: none"> • 2 alarm relays (ALL1-ALL2) • 1 alarm relay for sensor fault or working anomaly (FAULT) • output contacts capacity 5A-250Vac-res. • Arranged for output relays test
<p>TESTS AND PERFORMANCES</p> <ul style="list-style-type: none"> • Assembling in accordance with CE rules • Protection against electrical and magnetic noises: CEI-EN50081-2/50082-2 • Dielectric strength 2500 Vac for 1 min. from relay to sensors, relays to power supply, power supply to sensors • Accuracy $\pm 1\%$ full scale, ± 1 digit • Ambient operating temperature -20°C to $+60^{\circ}\text{C}$ • Humidity 90% no-condensing • ABS self-extinguishing housing-NORYL 94VO • Opt. Frontal plastic protection • Opt. Protection treatment of electronic part • Frontal in polycarbonate IP54 • Burben 3VA • Data storage: 10 years minimum • Digital linearity of sensors signal • Self-diagnostic circuit 	<p>DISPLAYING AND DATA MANAGEMENT</p> <ul style="list-style-type: none"> • 1 display 13mm high with 3 digits for displaying temperatures • 6 LED for displaying reference channel • LED indicating alarm or trip • LED indicating fault • Temperature monitoring from 0°C to 200°C • 2 alarm thresholds for each group of inputs (windings, bearings, air) • sensors diagnostic (Fcc-Foc-Fcd) • entering the programming by frontal push button • automatic output from programming cycle after 1 min. of no-operation • wrong programming automatic display programmed data call out • possibility of setting manual channel scanning or hottest channel • maximum temperatures storage • possibility to disconnecting air input (6CH) by programming cycle
<p>DIMENSIONS</p> <ul style="list-style-type: none"> • 96x96mm DIN43700 prof. 150mm (with rear terminals) • panel cutout 92x92mm 	

2) MOUNTING

Make a hole with the dimensions of 92x92 mm in the panel plate.
Fasten firmly the unit by the fixing blocks you are equipped with.

3) POWER SUPPLY

The MM-286 unit has an Universal Power Supply: it can be supplied indifferently from 24 to 240 Vac-dc without any respect of the polarities.
This particularity is obtained by the application of a tried power supplier which provides the installer free from the worries concerning the correct Vac or Vdc power supply.
The ground cable must be fixed to the clamp 41.

When the unit is supplied directly from the secondary of the transformers to protect, it can be fulminated by high intensity overvoltage (>240 Vac-dc - max limit).
This happens when the charge is connected with the locking of the master switch.
This is much more evident when the 220 Vac voltage is obtained directly from the bars of the secondary of the transformers and there is a fixed phase adjustment condenser of the same transformer.

*In order to protect the electronic apparatus, we suggest the application of the electronic discharges of the serie PT-73 - mono or double phase - which have been studied by Tecsystem Srl for this specific purpose.
Alternately, we suggest the application of a power supply by 24 Vac or better 24 Vdc.*

4) ALARMS ELECTRICAL CONNECTIONS

Carry out the electrical connections on the removable terminal board after having taken them off from the apparatus (follow the Fig.1).
ALARM and TRIP relays energize only when the prefixed temperature limits are reached (NO Fail Safe) or deenergize when the prefixed temperature limits are reached (Fail Safe).
The FAULT relay energizes always when the apparatus is powered and it de-energizes when the Pt100 are damaged or when there is not any power supply voltage.

5) MEASURE SIGNALS TRANSPORT

All the transport cables of the Pt100 measure signals must absolutely:

- be divided from the power ones
- be realized with shielded cable with twisted conductors
- have a section of min 0,5 mm²
- be twisted if you have not any shield
- be firmly fixed in the terminal board
- have tinned or silvered conductors

All the serie "T" units have the sensors linearization with a max error of 1% v.f.s..

*TECSYSTEM srl has realized a special cable for the measure signal transport with all the protection requirements in accordance with CEI Normes: **mod. CT-ES***

6) WARRANTY

The serie "MM" units are under warranty for 12 months from the delivery date signed on the unit.

The warranty is recognised when the unit breaks down due to some production faults or insufficient calibration.

The warranty is not valid when the unit is tampered with or when it has been damaged for a wrong sensors connection or wrong power supply, out of the max working limits (20÷270 Vac-dc). The warranty is not valid when the unit has been fulminated by excessive transitory voltages. In this case TECSYSTEM Srl does not answer for damages caused by faulted or defective units. All the delivery expenses (there and back) of the unit must be paid by the Customer

In case of dispute, the qualified FORUM is the one in Milan.

The warranty is always F.CO our Company in Corsico.

7) PT100 EXTENSION CABLE: TECHNICAL SPECIFICATIONS

Cable 20xAWG 20/19 cu/stg

Section 0,55 mm²

Antiflame Insulation PVC105

In accordance with CEI 20.35 IEC 332.1

Max. working temperature: 105°C

Conformation : 4 terns of numbered conductors (1-1-1.....4-4-4)

RRW twisted and coloured conductors

Cu/stg Shield

PVC Antiflame protecting covering

External diameter 9,0 mm

Skeins of 100 m

8) DISPLAY MODE

Pressing on DISPLAY MODE you establish the visualization ways of the display:

- *HOT* : the unit visualizes automatically the hottest channel
- *MAN* : manual reading of the channels temperature by UP and DOWN puch-buttons
- *T.MAX* : the unit visualizes the max. temperature reached by the sensors and the eventual alarms starting from last reset.
- *SCAN* : channels are cicley every 2 seconds

9) WORKING PROGRAM CONROL

In order to control the programmed temperature values, you have to push shortly on PRG. Pushing PRG repeatedly the values established precedently appear on the display in sequence.

In order to end the visualization you have to push ENT.

10) RANGE

Pressing "SET" button when the unit is on AUTOMATIC working, the ALL1 and ALL2 values appear on the display in sequence.

To have a more rapid channels scanning, you have to press many times the SET button. At the end it is carried out the LAMP TEST

11) LAMP TEST

It is advisable to carry out regularly the LED test of the unit. For this operation you have to push L.TEST.

If one of the LED does not work, please send us the unit in order to be repaired.

12) OVER TEMPERATURE (AUTO and MAN WORKING)

When one or more Pt100 sensors survey higher temperatures than the prefixed ones switch on:

- the GREEN led/s referred to the channel/s
- the led referred to ALL1 is YELLOW
- the led referred to ALL2 is RED
- and the ALL1-ALL2 relays commute

When the temperature is 1°C under the prefixed limit, the led switches off and the relay re-sets.

The over temperature alarm signal is intentionally delayed in order to avoid false alarms caused by temperature transitors.

The max. temperatures are any way memorized even if their performance time is not enough long to cause any alarm.

13) IMPORTANT NOTICE

Before making the insulation test on the electrical panel on which the unit is installed, you must take it off from the power supply in order to keep it out of damage.











14) PROGRAMMING REHABILITATION IN CASE OF BLOCK (Prg no)

If the programming has been blocked, in order to enter again the programming of the unit, it is necessary to carry out the following unblocking procedure :

- enter the program vision way pushing PRG
- keep TEST pushed until PRG stops to lighten. (LED PROGRAM alight)

During the blocking, pushing PRG for more than two seconds, on the display it appears "noP" to indicate the impossibility to program the data.

15) PROGRAMMING: LED PROGRAM SWITCH OFF: VISUALIZATION OF THE PROGRAM
LED PROGRAM ON: INPUT TO THE PROGRAM

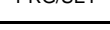
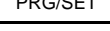
N°	PULSANTE	EFFETTO	NOTE
1	PRG/SET		Keep pressed the push button PRG/SET for 7" until stops to lighten to enter the programm.
2	PRG/SET	Start programming appears CH6	YES= 6 channels No= 5 channels
3	PRG/SET	Set T° of ALL1 of the windings appears	
4		set up the limit desired	
5	PRG/SET	set T° of ALL2 of the windings appears	
6		set up the desired limit	
7	PRG/SET	Set T° of ALL1 of the bearings	
8		set up the desired limit	
9	PRG/SET	Set T° of ALL2 of the bearings	
10		set up the desired limit	
11	PRG/SET	ONLY IF AT THE POINT "2" IT HAS BEEN ESTABLISHED YES	
12		Set up the limit of ALL1 for air	
13	PRG/SET	Idem point 8	
14		Set up the limit of ALL2 for air	
15	PRG/SET	set up Fcd YES or no	Fcd YES= control of damaged Pt100 connected
16	PRG/SET		ONLY IF opt. RS232/RS485
17		set up the Baud rate (E:parity Even, n:parity none)	Baud rate: E1.2 - E2.4 - E9.6 - E19.2 n1.2 - n2.4 - n9.6 - n19.2
18	PRG/SET		ONLY IF OPZ. RS485
19		set up address for opt. RS485	from 0 to 32 max
20	PRG/SET	on display appears Prg	
21		set up Prg YES or no	Prg no= the programming is blocked
22	PRG/SET	set up the function of the ALARM relay	
23		function for ALARM	Fail Safe YES - Fail Safe NO
24	PRG/SET	set up the function of the TRIP relay	
25		function for TRIP	Fail Safe YES - Fail Safe NO
26	PRG/SET	on display appears HLd	
27		set up HLd YES or no	with HLd YES function HOLD established
28	PRG/SET	return to step 1	
29	ENT	out of the programming	lamp test

16) FAULT

The MM-286 monitoring unit is provided with a self-diagnostic program with alarm relay and visualization of the kind of fault of the sensors.

An additional program allows to distinguish a high temperature signal given by an eventual defective sensor. In this case the FAULT relays commutes and on the display appears Fcd with the relative defective sensor.

This particular program avoids the signalization of accidental alarms due to defective sensors which indicate wrong temperature values.

17) THERMOMETRIC SENSORS DIAGNOSTIC

In the event one of the thermometric sensors installed on the machine to protect is damaged, the FAULT relay energizes immediately, the ALARM and TRIP LED's of the damaged channel (Chr) lighten and the FAULT LED is lightening.

The screen will automatically display a message showing the fault condition:

- Fcc sensor is short circuited
- Foc sensor is open
- Fcd sensor is fault

18) ALARM RELAYS TEST

This function allows to test the relays working without any additional instrument.

To carry out the test you have to push TEST for 5 seconds: all the LED will switch on and on the display will appear tSt lightening.

Release it when the RELAY TEST LED will be alight.

The first relay to test will be indicated by the display and the respective LED will be alight.

The relays to test will be indicated on the display by:

- "FIt" : Pt100 fault relay
- "Alr" : alarm relay
- "AI2" : trip relay

Select the relay to test by UP and DOWN push-buttons. Energize it pushing SET and de-energize it pushing RESET.

In order to stop this procedure, you have to push again TEST and all the relays will be restored to the starting configuration.

After 5 minutes of inactivity of the keyboard, the TEST RELAY procedure will be automatically interrupted.

19) ALARM RELAY EXCLUSION

If you want to exclude the alarm signal, you have to push RESET: the relay de-energizes and the respective LED, which was alight, starts to lighten. If the transformer temperatures is still rising, the ALARM relay will energize again until to have a temperature value of 5°C less than TRIP threshold. In this moment the user can exclude again the ALARM, but in this case, it will not appear any other indication as regards ALARM relay.

The exclusion system will be automatically disconnected when the temperature falls down the ALARM threshold.

FAULT DIAGNOSTIC	CAUSES AND REMEDIES
The unit doesn't switch on even if there is voltage to the terminals	Connector not well fit in its place. Connection wires not well closed in the clamp Burnt power supplier. <i>Take away and give again voltage.</i>
The sensor is damaged	The FAULT relay closes and the FAULT LED switches on. The RED LED of the relative channel is lightening. It is indicated on the display the kind of damage of the sensors: <i>FOC= sensor open</i> <i>FCC= sensor in short circuit</i>
One of the five/six channels is in FAULT for FOC/FCC	Check the Pt100 sensors connection. Probable damaged sensor. <i>Replace the damaged sensor</i>
During the main switch manoeuvre ON-OFF, the L1 and L2 relays energize	Strong electrical noises on the power supply line. <i>Plug in the PT-73.</i> Check if the shield of the signal transport cable is connected to the ground in the side of the panel. <i>If you have not any shielded cable, You have to put it. (Mod. CT-ES).</i> <i>If it is not at your disposal, twist the three connecting wires of the sensors.</i>
All the Pt100 sensors are in FCC.	Wrong connection of the sensors. Upside-down terminal board. <i>Check the connections and the terminal board</i>
The temperature indicated by 1 or more channels is wrong.	Pt100 Sensor/s defective. <i>Check the sensor resistance by an Ohmetro.</i> Unit with input circuit unrated. <i>Send the unit to TECSYSTEM S.r.l. for reparation.</i>
With power supply at 24 Vdc, the unit switches off and , after a tension drop, it doesn't switch on again.	<i>Take off the voltage to the unit and check that the value of the Vdc is from 20 up to 24V.</i> <i>Give again voltage.</i> <i>If the unit does not switch on , send the unit back to TECSYSTEM S.r.l.</i>
Sudden release of the main switch with a normal temperature level. An only channel caused the unhooking.	Pt100 sensor defective (Fcd). <i>Replace the sensor.Check the measure signal terminal board.</i>

FIG.1 ELECTRICAL CONNECTION

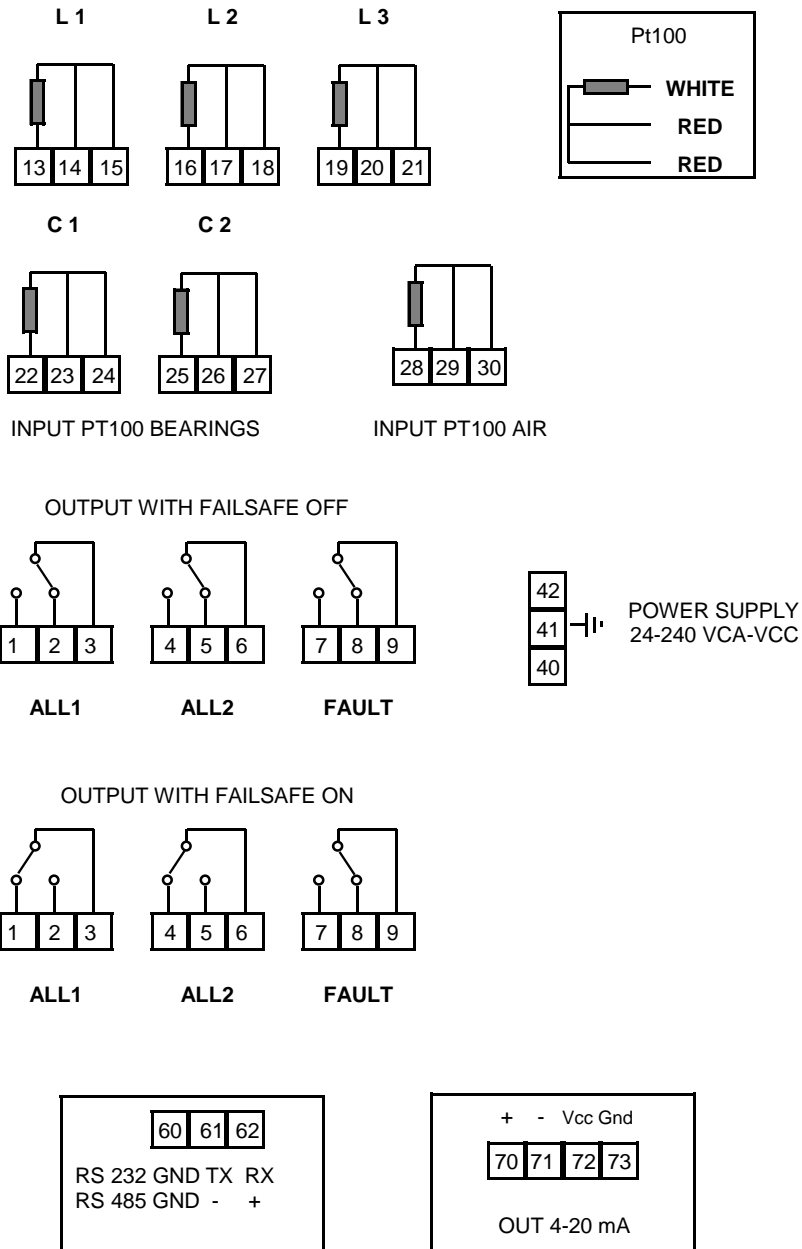

MM-286 TEST DESCRIPTION

The unit was submitted to the following tests during production:

N°	Description
1	PC board test
2	Input test
3	Test of relay contacts and outputs
4	Key test
5	Lamp test
6	Calibration at 100 and 200°C (for temperature monitoring units)
7	Software test
8	Burn-in minimum 24h

Date of shipment: